

General Specifications

VJD1 Tachometer (Isolated Single-output and Isolated Dual-output Types)



GS 77J01D01-01E

General

The VJD1 is a compact, plug-in tachometer converter that receives single-phase, AC voltage signal from an electric tachometer and converts it into isolated DC voltage or DC current signals.

- AC-to-DC conversion based on mean-value rectification;
- four isolated ports (input, output-1, output-2, power supply and grounding) on a dual-output model;
- a withstanding voltage of 2000 V AC;
- a wide supply voltage range - supporting both 100 V and 200 V power lines of AC or DC; and
- close side-by-side mounting.

Model and Suffix Codes

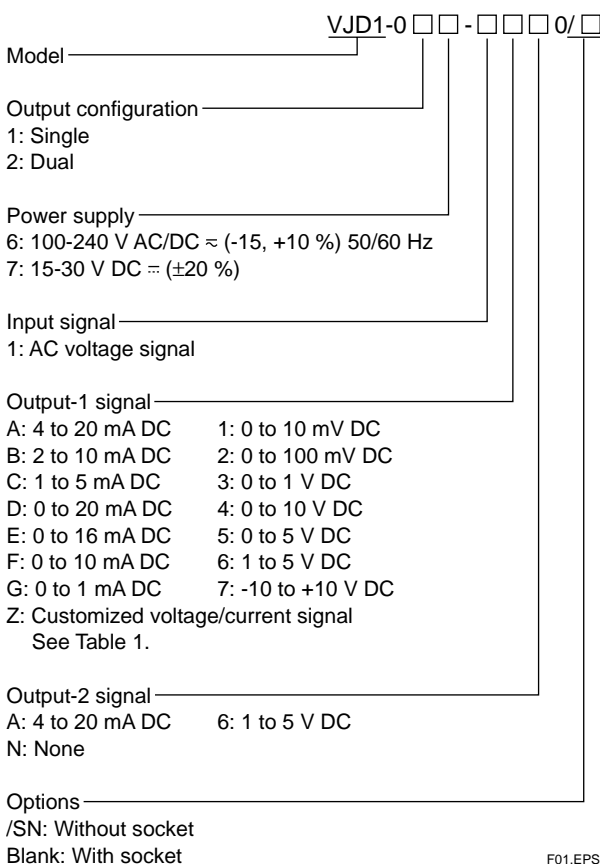

Input/Output Specifications

Type of input: 0 to V_{100} V AC (V_{100} : voltage for 100% input)

where, $16 \leq V_{100} \leq 150$ V AC.

Input frequency range: $15 \text{ Hz} \leq F_{100} \leq 1 \text{ kHz}$ (F_{100} : frequency for 100% input)

Maximum allowable overrange input: 120% (continuous)

Output signal: DC voltage or DC current

Allowable load resistance:

Output 1

Output Range	Output Range
4 to 20 mA DC: 750 Ω maximum	0 to 10 mV DC: 250 k Ω minimum
2 to 10 mA DC: 1500 Ω maximum	0 to 100 mV DC: 250 k Ω minimum
1 to 5 mA DC: 3000 Ω maximum	0 to 1 V DC: 2 k Ω minimum
0 to 20 mA DC: 750 Ω maximum	0 to 10 V DC: 10 k Ω minimum
0 to 16 mA DC: 900 Ω maximum	0 to 5 V DC: 2 k Ω minimum
0 to 10 mA DC: 1500 Ω maximum	1 to 5 V DC: 2 k Ω minimum
0 to 1 mA DC: 15 k Ω maximum	-10 to +10 V DC: 10 k Ω minimum

Output 2

Output Range	Output Range
4 to 20 mA DC: 350 Ω maximum	1 to 5 V DC: 2 k Ω minimum

Zero and span adjustment: Within \pm 5% of span for both zero and span adjustment

Items to be specified when ordering

- Model and Suffix Code: e.g. VJD1-026-1AA0
- Input range: e.g. 0 to 35 V AC

■ Standard Performance

Accuracy rating: $\pm 0.3\%$ of span; accuracy is not guaranteed for output level less than 0.5% of the span of a 0 to X mA output range types.

Response: 2.4 sec. for a 63% response (10 to 90% change of range)

Insulation resistance: 100 M Ω minimum at 500 V DC between input, output-1, output-2, power supply and grounding terminals mutually

Withstanding voltage: 2000 V AC for one minute input, (output-1, output-2), power supply and grounding terminals mutually;
1000 V AC for one minute between output-1 and output-2 terminals

Operating temperature range: 0 to 50°C

Operating humidity range: 5 to 90% RH (no condensation)

Supply voltage range: 100-240 V AC/DC \approx (-15, +10%)
50/60 Hz or 15-30 V DC \approx ($\pm 20\%$)

Effects of power line regulation: Up to $\pm 0.2\%$ of span for a supply voltage range of 85 to 264 V AC (47 to 63 Hz), 85 to 264 V DC or 12 to 36 V DC

Effects of ambient temperature variations: Up to $\pm 0.2\%$ of span per 10°C

Current consumption: 122 mA at 24 V DC

Power consumption: 5.4 VA at 100 V AC; 7.5 VA at 200 V AC

■ Mounting and Appearance

Material: ABS resin (casing)

Mounting: Wall mounting, DIN rail mounting, or mounting on a side-by-side multiple mounting base

Connection: Terminals with M3 size screws

External dimensions: 76 (H) \times 29.5 (W) \times 124.5 (D) mm

Weight: Main unit = approx. 110 g; socket = approx. 51 g

■ Accessories

Tag number label: One

Customized Signal Specifications

Table 1 Manufacturable Ranges

	Current Signal	Voltage Signal
Input range	–	0 to 150 V AC
Span	–	16 mV to 150 V AC
Zero elevation	–	0% only
Output range	0 to 24 mA DC	-10 to +10 V DC
Span	1 to 24 mA DC	10 mV to 20 V DC
Zero elevation	0 to 200%	-100% to +200%

T01.EPS

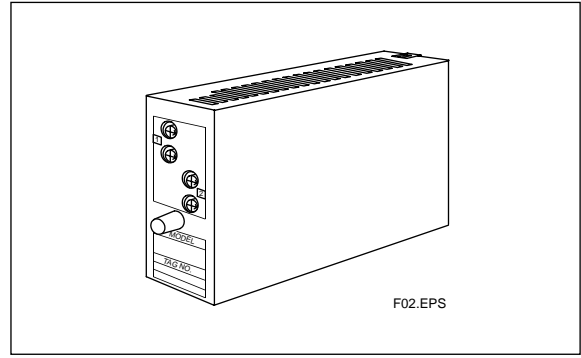

Terminal Assignments

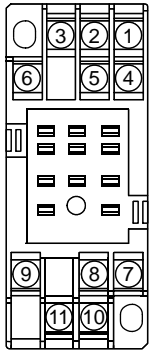

1	INPUT	(V)
2	OUTPUT 2	(+)
3	INPUT	(±)
4	N.C.	
5	OUTPUT 2	(-)
6	N.C.	
7	OUTPUT 1	(+)
8	GND	
9	OUTPUT 1	(-)
10	SUPPLY	(L+)
11	SUPPLY	(N-)

Note: For single-output models, OUTPUT2 is N.C.

F03.EPS

Block Diagram

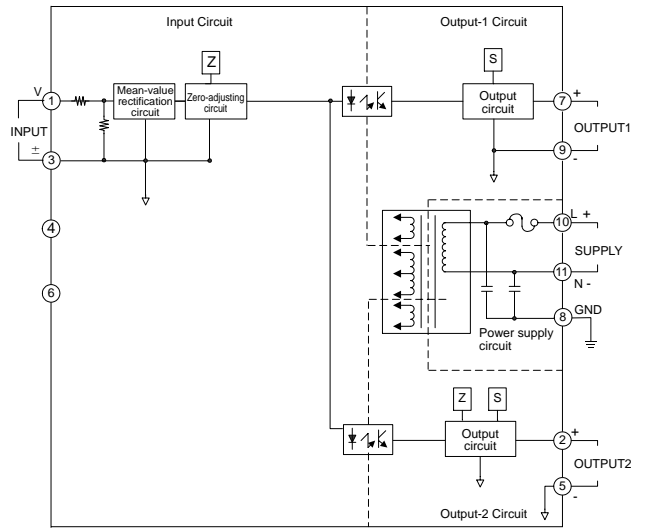

Note: Single-output models do not contain the output-2 circuit.

F04.EPS

External Dimensions

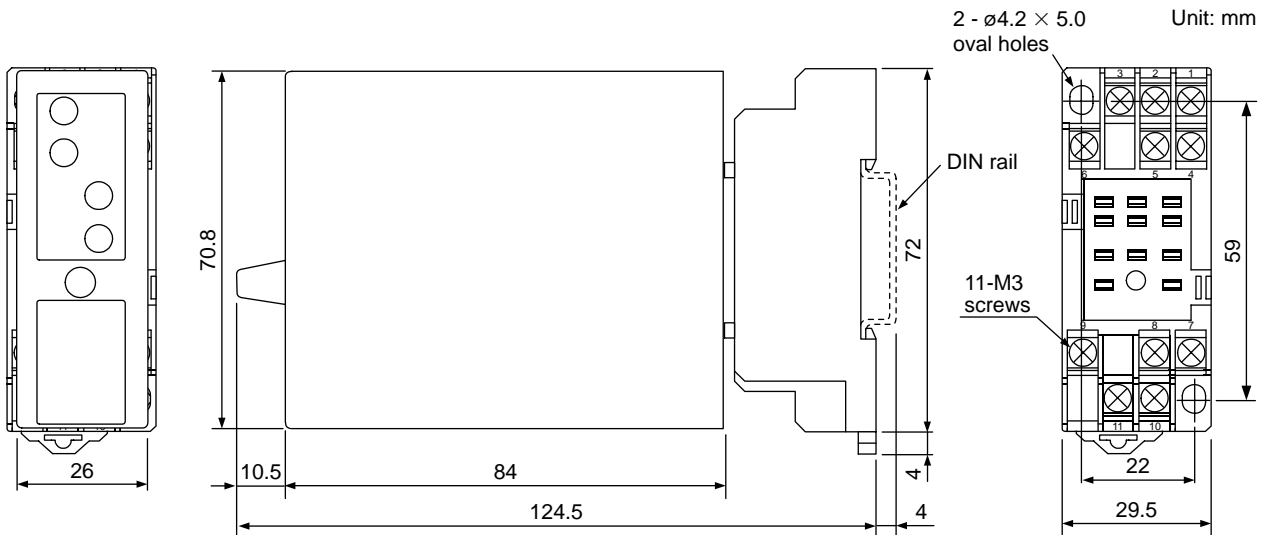

F05.EPS

- The information covered in this document is subject to change without notice for reasons of improvements in quality and/or performance.